

| USER MANUAL

PXiD

Tips: Please read this manual carefully before use and keep it properly.
Do not ride until you know the performance of this product.

Welcome

Thank you for choosing PXID Cheetah P5 fat tire electric bike (hereinafter referred to as Cheetah P5). This bicycle is a safe and fashionable transportation tool. Enjoy free riding and speed control from now on!

In order to ensure the safety, please read this manual carefully before riding to meet the relevant conditions.

Join PXID Cycling Club and we look forward to meeting you on social media!



Pxid Bike



Bike Pxid



pxid_bike



@PxidBike

Tag us! @PXID #PXID

Contact us

Company: Huaian PX Intelligent Manufacturing Co.,Ltd.

Add: No.18, Shenzhen East Road, Qingjiangpu District, HuaiAn, JiangSu

Email: inquiry@pxid.com

Website: www.pxid.com

Content

1. Safety instructions	02
2. Products and accessories	05
3. Function diagram	06
4. How to assembly	10
5. Check before riding	13
6. How to ride	14
7. How to charge	15
8. Product specifications	17
9. Daily maintenance	18
10. Warranty service	23
11. Trademarks and legal statements	24

1. Safety instructions

1. Electric bikes are a recreational product. In order to ensure the safety of cyclists, please read this manual carefully before using this product, practice and master the riding skills through the correct guidance. If the rider is inexperienced or does not use in accordance with this manual, the company (the company refers to Huaian PX Intelligent Manufacturing Co., Ltd. and its affiliates) will not bear any responsibility for any damage.

2. Please follow local laws and traffic regulations. Do not ride electric bikes in areas where they are prohibited by law. Do not ride electric bikes on public transport roads. Do not ride on the road infested with motor bikes under any circumstances, otherwise serious injury or death may result.

3. There is a risk of injury or death from loss of the electric bike control, collisions and falls when using electric bike. To reduce risk, riders must read and follow all "cautions" and "warnings" in the instructions. Following the warnings and tips in this manual reduces risk, but does not eliminate all risk. Please ride with caution and knowledge of driving.

4. This product must be assembled and adjusted by the rider's guardian or other adult. This product should not be accessible to people under 16 years of age.

5. The package contains wrenches, plastic bags and other items. Please keep them away from minors.

6. Do not give the electric bike to someone who cannot operate it. Please ensure that others are aware of the correct usage of this product before giving it to them for use. You are responsible for the safety of new riders. Please assist him/her in learning to use the product until he/she has learned the basic operation. Please ensure that each new rider wears a helmet and other protective gear and uses them if a guardian is required. Please deliver the product with this instruction when you hand it over to others.

Riding environment and pavement

1. Avoid riding on steep slopes, bumpy roads, slippery roads, pits, sewage openings, stairs, snow, water edges, near furnaces, flower beds, expansion joints, construction roads, debris and other obstacles. When riding, you should observe and avoid traffic at any time, and try to keep a safe cycling

speed. Too fast cycling is prone to accidents such as bike losing control and falling injury.

2. For whatever reason, do not ride in snowy, rainy, slippery, muddy, or icy conditions. Doing so could cause the bike to lose its balance or grip, leading to a fall. Riding in rainy weather can cause water to enter the bike, leading to the risk of functional damage, fire or even explosion due to the wet battery. Damage and loss due to water intake are not covered by the warranty.

3. Please do not ride in bad weather or poor visibility (e.g. at night).

Riding precautions

1. Only one person is allowed to ride the electric bike/scooter. Overloading is strictly prohibited!

2. Please wear helmets and knee and elbow pads when riding. Please use a good quality bicycle or scooter helmet.

3. Grip the handlebars with both hands when riding. Do not hang ornaments, heavy objects, etc. from the handlebars.

4. Do not speed up or slow down suddenly while riding. Please do not go faster than the e-bike/scooter limit.

5. When riding, avoid putting your hands and feet into the rolling wheel.

6. When riding, please pay attention to the road conditions and avoid obstacles and roads that are not easy to ride (including but not limited to slippery ground, loose sand, gravel ground and ice).

⚠ Warning

If the electric bicycle gives out abnormal sound or alarm sound, please stop using it immediately, and call the after-sales service number 400-853-2909 to obtain professional guidance or maintenance service.

Rider requirements

People who are not suitable to ride this product include:

I. Persons under the influence of alcohol or drugs.

II. Persons who are unable to perform strenuous physical activity due to medical conditions, especially those with heart, neck, back, etc.

III. People who can't keep their balance.

IV. Persons whose age, height and weight are not within the prescribed limits.

V. Persons with limited intelligence who are unable to understand the proper use of electric bicycles and the associated risks.

Operation notice

1. Only parts and accessories designated or approved by the company can be used. Do not modify the electric bike, otherwise it may affect the operation, leading to serious injury/damage and warranty void. Electric bicycle contains electrical components, do not remove.

2. Do not drive the electric bike when the ambient temperature exceeds the operating temperature of the product (please refer to the "Product specifications"), because low/high temperature will lead to the limitation of the maximum power and the degradation of the product performance. Doing so may cause a slip or fall, or even result in personal injury or property damage.

3. Please do not let minors touch fenders, wheels and other structures with gaps. Do not touch the brake or hub motor after riding to avoid burns caused by elevated component temperature.

4. Please park the electric bike on the flat and firm road as much as possible. It is recommended to park near the wall. Do not park in busy areas. If parked on the slope, the electric bicycle foot support must be oriented downhill to prevent overturning. Please do not let the electric bicycle head down, to prevent the kickstand closed and bike fall over under the action of gravity. After putting down the kickstand, please check whether the body of the bike is stable, to prevent the bike from falling over(due to sliding, wind or shaking etc.).

5. Regular maintenance of product is recommended for a better driving experience (see "Daily care and maintenance").

6. Users must read the charging steps and precautions in this manual before charging (please refer to "How to Charge").

2.Products and accessories

Carton 1:

User information

User manual

User manual

Warranty

Certification

Warranty

Certification



Handlebar×1



Pedal×2

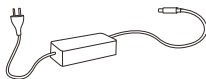

Charger×1



Allen×4



Headlight×1



Saddle×1

Carton 2:

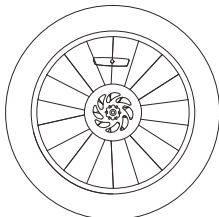

Front wheel×1

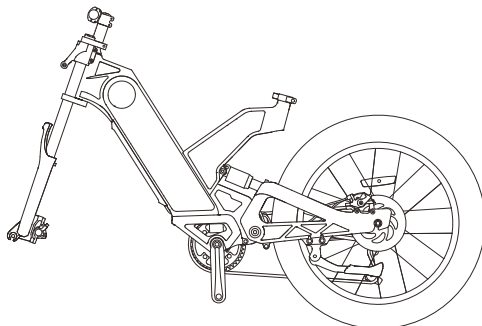

Bike body×1

Due to packaging needs, the front wheel is packaged separately. Please carefully check whether the items in the packaging box are complete and in fact of any missing or broken items.

3.Function diagram

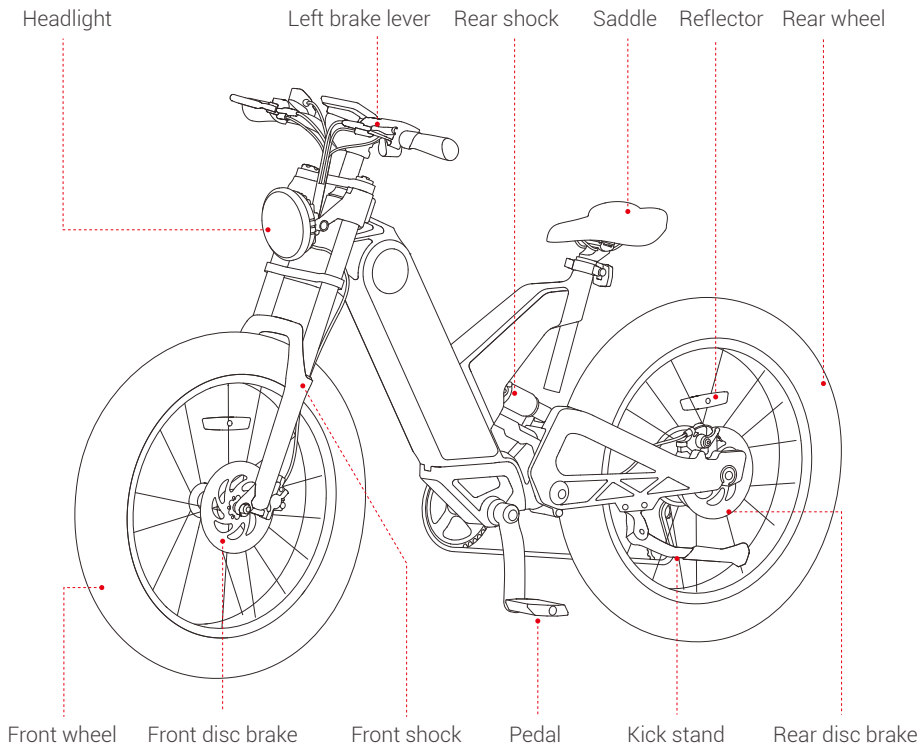

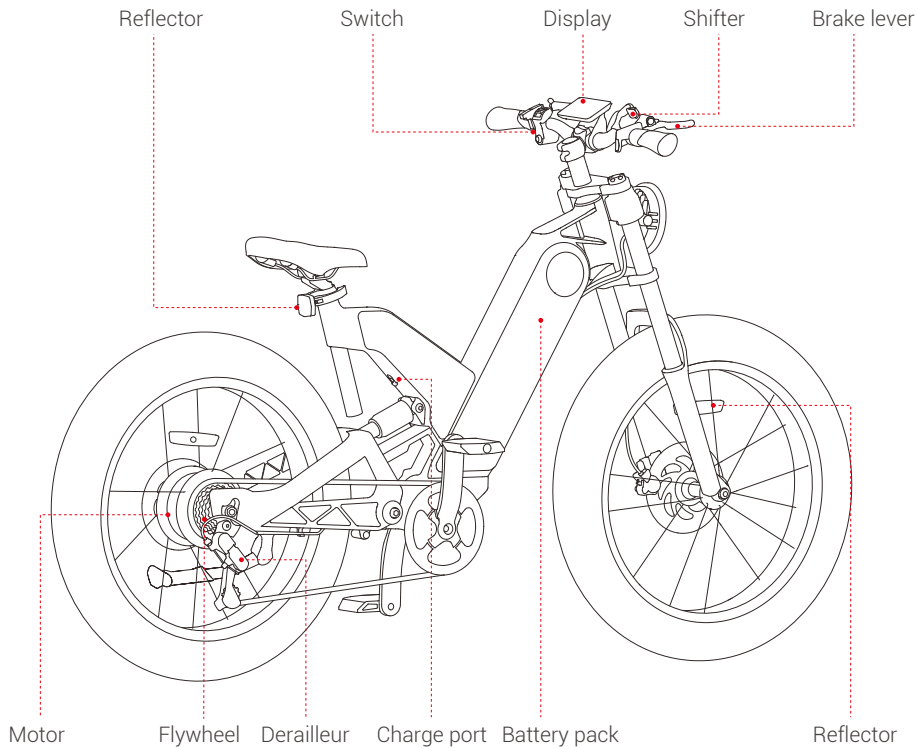



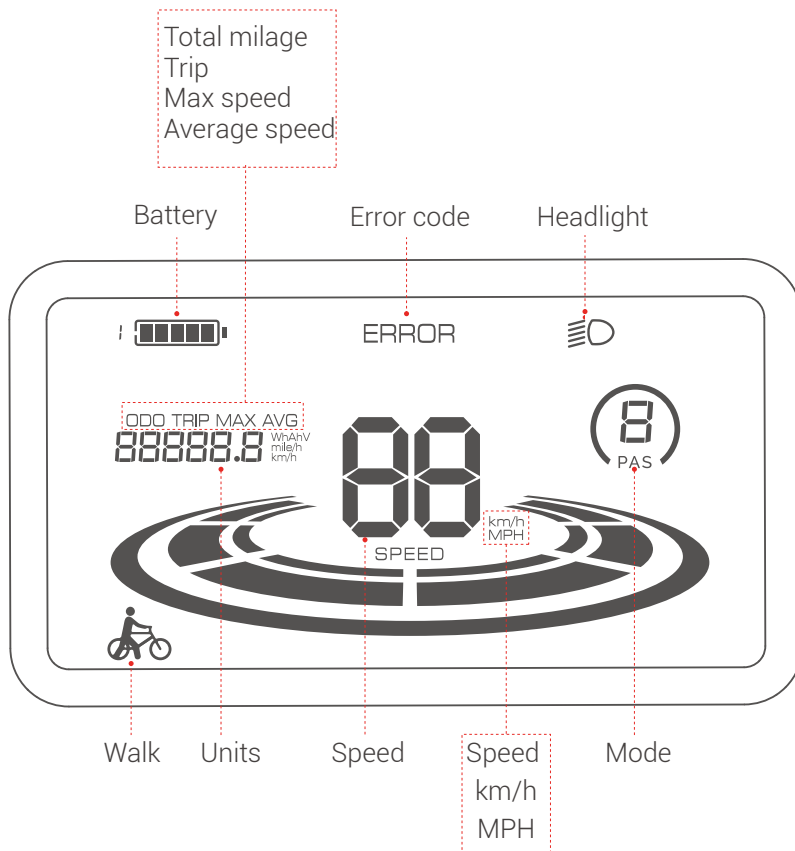

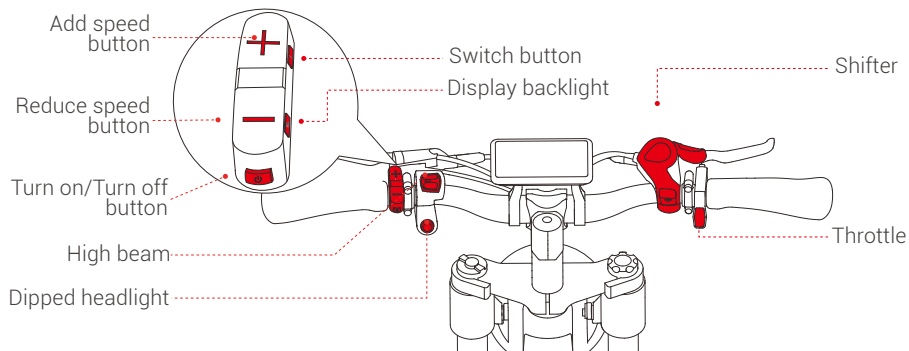

Display



Head combination switch



	Turn on/ Turn off button	Long press to start working and power the controller. In the boot state, long press the button to turn off the power supply.
	Add speed button	Short press key to switch the electric vehicle power gear to change the output power of the motor.
	Reduce speed button	Long press to a power implementation state, the bike travels at a constant speed of 4 km/h Also, screen display works. Release the button immediately returns to the booster state.
	Switch button	Short press the key display information switches between the total mileage (km), single mileage (km), maximum speed (km /h), and average speed (km / h).
	Display backlight	Press the display backlight button, the backlight off. Press again, the backlight on.



In the factory default setting, if the electric vehicle is not used for more than 10 minutes, the instrument will automatically shut down.

4.How to assembly

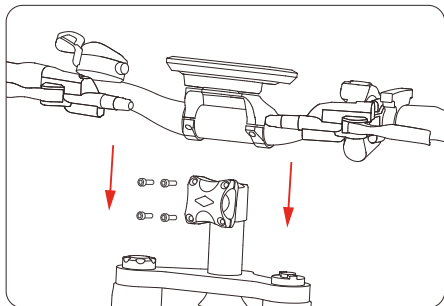

1. Fix the front, unscrew the screws on the slot first, and correspond the horizontal kit to the slot.

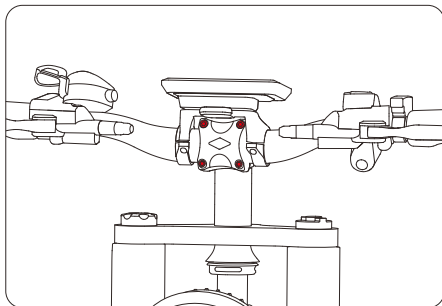

2. Secure the horizontal kit, tighten it with a hexagon screwdriver, and finish the installation, as shown in the figure above.

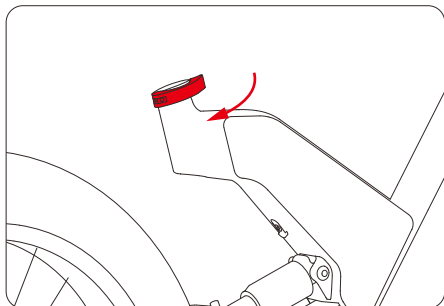

3. Install the saddle, open the lock and insert the saddle first.

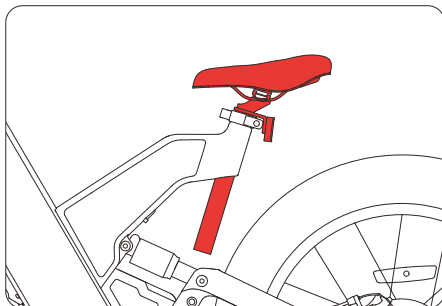

4. After the saddle is inserted, make sure that the seat does not turn back, do not shake, and the lock is tightly fixed.

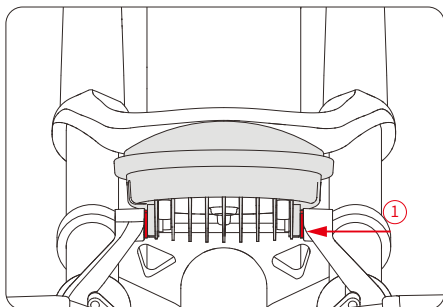

5. Place the gasket ① inside of the bracket, pass through the screws, and install the headlights.

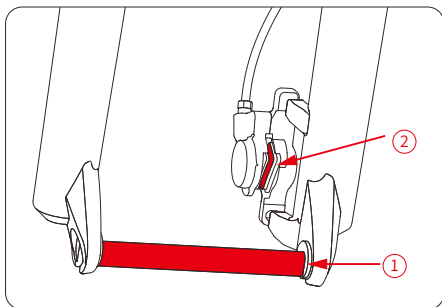

6. Remove the front fork protector rod ① and the front splinter protection plate ② as above.

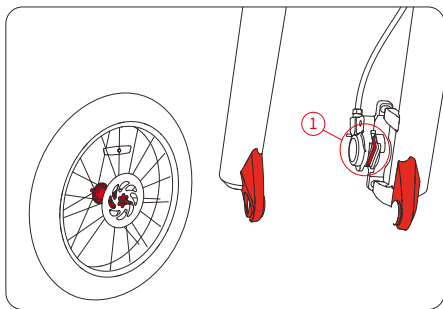

7. Place the wheel brake disc at the front clip ①, and point the wheel snap release lever at the front fork card slot.

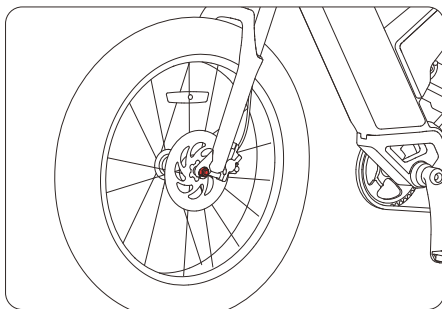

8. Put the wheels right and check the gap between the brake disc and the clamp, after the installation, tighten the nuts on both sides.

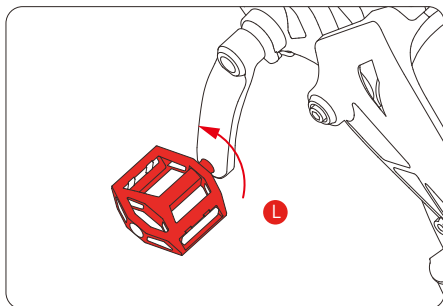

9. Install the pedal, to left and right sides of the foot, and twist the left one counterclockwise.

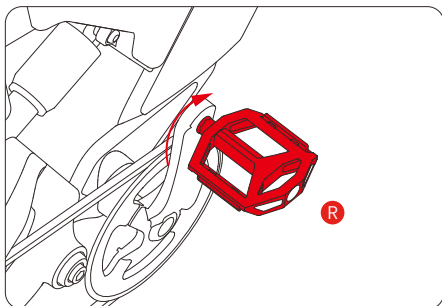

10. Turn the right foot clockwise and slowly spin in, tighten it with a wrench, so as not to cause slippery teeth.

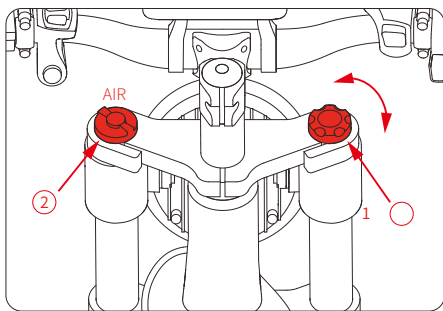

11. As shown the circular knob ① rotates clockwise to the head, the front fork is locked, rotates counterclockwise to the head, and the front fork restores shock absorption; AIR ② rotation is forbidden.

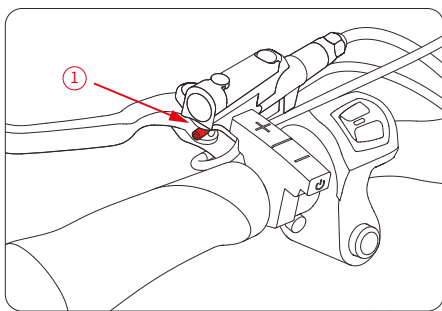

12. As shown in the figure, the oil brake has a built-in screw ①, which can adjust the grip distance.

5. Check before riding

To reduce the occurrence of accidental injuries, the following items should be checked before each ride:

1. Check bike status, tire and brake effect, etc. Ensure that no parts including the handlebars, risers, tires, brake lines, brake handles, fenders, and screws show any signs of loosening or damage.
2. When the power is low, the electric bike / scooter does not have enough power to maintain normal cycling. Please make sure that the power is sufficient to avoid danger.
3. Must wear a helmet and a full set of knee pads, wrist pads, elbow pads, wear sports shoes, and wear clothes suitable for sports. Long hair or enough to affect the line of sight bangs, broken hair should be tied up, so as not to block the line of sight affect normal riding.
4. For your first ride, please do not choose the areas where children, pedestrians, pets, vehicles or other obstacles and potential hazards may occur.

Note: If there are any abnormal signs, please stop using it immediately and contact the after-sales service for testing guidance.

6. How to ride

1. Preparation:

There is a risk of falling and injury, so wear a helmet and protective gear all the time.



Helmet

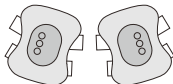

Protective

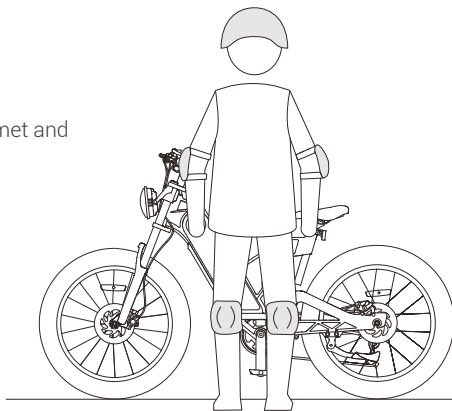



2. Operating: Press on/off to unlock and power on; and check battery status, if the charge is too low, please charge it immediately.

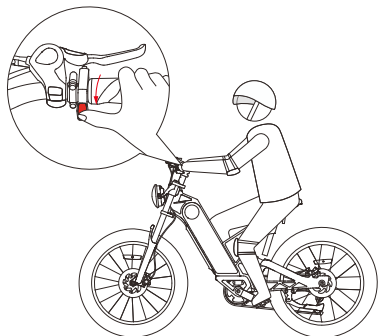

3. Start: Adjust the sitting position, slowly press the accelerator at speed gear; pedal it after balancing.

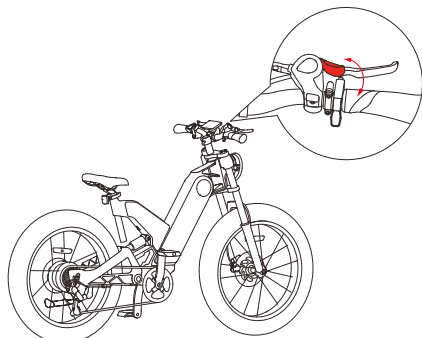

4. Speed up: Push shifter can perform from 1 to 7 gears.

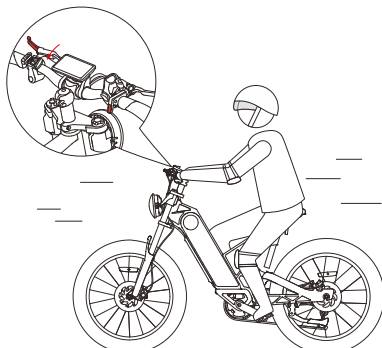

5. Slow down and brake: Release the throttle and slow down. Emergency brake requires a quick press on the brake lever.

Warning: Quick braking may fall due to insufficient.

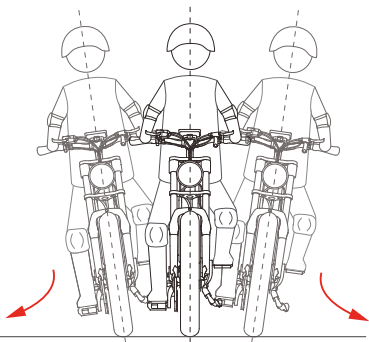

6. Turning: When turning, lean your center of gravity slightly and slowly turn your handle.

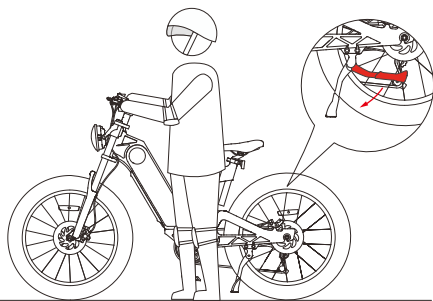

7. Get off: After cycling, please park the bike on the flat road and long press on to turn off the power; drop the foot support to avoid slipping or falling.

7.How to charge

Due to the self consumption of the battery during transportation and storage, it is normal the low or no power for the first time. Please follow the charging steps below. Do not allow child to operate the charging equipment.

Charge:

Find the charging port above the rear shock absorber, open the rubber plug of the charging port, connect the output end of the charger, then connect the power supply, and fasten the rubber plug after charging.

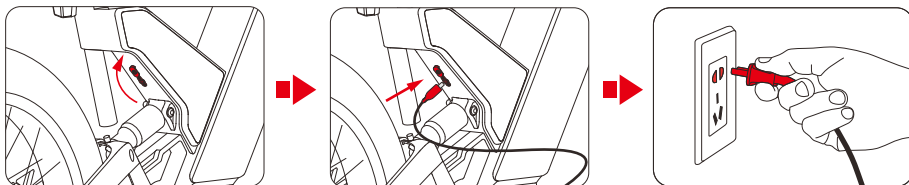

*The red light of the charger means the charger is working. The green light means the charging is finished. Please cut off the power after the battery is fully charged. If the temperature of the vehicle body exceeds 40 C, the vehicle will not be charged normally. Please wait until it drops below 40 C before charging.

▲ Warning

1. Please charge when the bike power off.
2. Please use the original charger and only use the charger designated or approved by the supplier, otherwise the battery may be damaged or ignited.
3. Do not charge when the charging port, power socket or charging line is wet. If the vehicle is flooded, the battery is damaged or flooded, it is prohibited to charge or continue to use the battery.
4. In the process of charging, if the indicator light is abnormal or there is abnormal smell, stop charging immediately and contact the after-sales service or replace the charger.
5. The charger shall be kept away from inflammables and explosives when working. The charger is not a toy. Please place it in a safe place where child cannot touch.
6. Disconnect the power immediately after charging. Do not connect the charger to the power supply for a long time when it is not charged.
7. It is necessary to regularly check whether the charger wires, plugs, housings and other parts are damaged. In case of damage, it shall be stopped use until it is repaired or replaced.

8.Product specifications

Model	Cheetah P5
Colour	Dark Grey / OEM color
Maximum battery capacity	16Ah (main) / 20Ah (customizable)
Maximum range	65km
Motor	48V 750W
Tire	24*4.0 inches
Standard working voltage	48V
Battery Type	Lithium battery
Brake	Front & rear oil disc brake
Rated maximum load	150Kg
Lights	Headlights (functions include position lights, low beam, high beam)
Net weight	38.5kg
Gross weight	43.5kg
Front wheel packing gross weight	6.0kg
Expanded size	1850*700*1070mm(L*W*H))
Storage temperature	0°C~35°C
Charging temperature	10~35°C

You can choose the appropriate version according to your own needs. Cheetah P5 will launch various optional upgrade accessories and color style kits in the future. For details, please consult your dealer.

9. Daily maintenance

Users should follow the following tips to maintain and maintain electric bicycles:

Clean

Wipe the main frame clean with a soft damp cloth. For hard-to-clean stains, use a professional cleaner to scrub repeatedly, then clean with a soft damp cloth.

Note: Do not use alcohol, gasoline, kerosene or other corrosive and volatile solvents to clean. These substances may damage the exterior and interior structure of the vehicle body.

⚠ Warning

- Do not use pressure water guns or hose sprays for flushing.
- During the cleaning process, keep the electric bicycle turned off, unplug the charging cable and fasten the rubber cover of the charging port, otherwise it may cause electric shock or serious failure due to internal water.

Storage

When not in use, try to store it in a dry and cool place indoors, and try to avoid storing it outdoors for a long time. Sun exposure/hot/cold outdoor conditions will accelerate the aging of the appearance and tires and reduce the service life of the body and its battery pack. Before storing, please fully charge the electric bicycle, if it is not used for a long time, please charge it regularly to prevent the battery from discharging. Do not store it in a dusty environment to avoid damage to electrical components. Can not be stored together with chemicals, acids, alkalis and other substances.

⚠ Warning Do not go near the fire source!

Move

Before moving, make sure that the electric bicycle is turned off. During the handling process, please handle with care, do not throw, heavy pressure, rain, moisture and violent collision are strictly prohibited.

Battery Maintenance and Recycling

A well-maintained battery will keep running well even after many miles of driving. Generally speaking, a fully charged battery will use up its stored power in 120-180 days after it is turned off. If it is not used for a long time, it should be charged every 30-60 days. Charge the battery after each drive. A completely depleted battery may cause permanent damage. There is a smart chip inside the battery to record the charge and discharge of the battery. Damage due to over charging or undercharging is not covered under warranty.

- Do not remove or disassemble the battery.
- Do not use other types or brands of battery packs, otherwise there may be safety risks.
- It is forbidden to charge in areas that are prohibited by the laws of the country/region and relevant management units.
- Do not touch the battery contacts and do not open or puncture the case. Avoid metal objects touching the battery contacts to cause a short circuit, otherwise it may cause battery damage or personal injury.
- Do not throw the battery pack into a fire, otherwise it may cause the battery to fail, overheat, or even risk a fire.
- When storing or charging the battery, do not exceed the specified temperature limits (see "Product Specifications").
- Improper disposal of used batteries can seriously pollute the environment. Waste batteries cannot be dismantled without authorization, and should be recycled by relevant professional departments. Please comply with local regulations and do not discard the battery pack arbitrarily to protect the natural environment.

Charger

- Chargers should be used exclusively for vehicles, and it is strictly forbidden to charge non-rechargeable batteries;
- Confirm whether the connected power is 110V-220V AC power;
- If you find damaged lines or loose connectors, do not use them, please contact the after-sales service or designated authorized service;

- When charging, the vehicle should be in a safe place, beware of rain and sun exposure;
- When charging, insert the vehicle's charging port first, then the charger's power plug;
- During the charging process, if the indicator light is abnormal, there is a strange smell or the charger case is overheated, the charging should be cut off immediately;
- After the battery is fully charged, unplug the charger first, and then unplug the charger;
- After the charger has cooled down, tidy up the power cord and charging cable and place them in a safe place;

Other

- When the brake cable is loose or the brake is not sensitive, the brake cable screw can be adjusted.
- The external cord of the charger cannot be replaced. If the cord is damaged, please replace the charger in time.
- Tire repairs should be performed by professional service personnel.

Self Maintenance Guide

- 1.The first maintenance shall be carried out 1000 km after delivery of the new bike or 3 months after delivery (which ever comes first).
2. After the first warranty, it is recommended to maintain once every 2000 km or 6 months (whichever comes first).

Specific maintenance rules and items and requirements

Maintenance project	Maintenance time (month)	3	9	15	21	27	33
	Maintenance mileage (km)	1000	3000	5000	7000	9000	9000
Adjust or replace front and rear brakes		A	A/R	A	A/R	A	A/R
Check handlebar steering		C	C	C	C	C	C
Check the tire pressure		C	C	C	C	C	C
Check the disc brake system		C	C	C	C	C	C
Tighten main component		T	T	T	T	T	T
Lubrication of main parts		L	L	L	L	L	L
Front and rear shockabsorption adjustment		A	A	A	A	A	A
Check Light system		C	C	C	C	C	C
A: Adjust C: Check L: Lubricate T: Tighten R: Replace							

Error code meaning sheet

Error number	Error Problem		Error number	Error Problem
E001	Controller error		E004	Throttle error
E002	Communication error		E005	Brake error
E003	Hall error		E006	Motor error

10. Warranty service

1. Warranty parts

Type	Warranty parts	Time
Body frame	Frame	2 year
Spare parts	Battery, motor, controller, charger	1 year
Appearance delicate parts	Handles, front and rear fenders, crank chains, reflective stickers, seat pads, brake pads	3 months

2. Non-warranty provision

1. Unauthorized maintenance, misuse, collision, negligence, abuse, liquid entry, accident, change, incorrect use of accessories other than this product, or tear, change or anti-counterfeit labels;
2. The warranty period has expired;
3. Damage caused by force majeure;
4. It does not meet the conditions of performance failure listed in the following "Electric bike performance error sheet";
5. Failure to use, maintain and adjust in accordance with the requirements in the "Instruction Manual" will lead to performance failure of e-bike;
6. Damage caused by human causes (including but not limited to punctured tires, collisions, marks and damage caused by normal use of appearance delicate parts, etc.);
7. Failure and damage caused by abnormal use of the product (including but not limited to overload, stepping down, falling, extreme sports, etc.);
8. If the Product is used for commercial purposes, there is no warranty.

3. Electric bike performance error sheet

Product	Performance error
Electric Bike	<ol style="list-style-type: none">1. The motor can't work during normal use;2. The controller is faulty during normal use;3. The charger error during normal use;4. The battery is error during normal use;

11. Trademarks and legal statements

1. Trademark and Copyright law Statement

PXID is a registered trademark of Huaian PX Intelligent Manufacturing Co., Ltd. Android is a trademark of Google; AppStore is Apple's service trademark; Other trademarks mentioned in the text belong to their owners. This manual has been printed as much as possible to include the introduction of various functions and instructions. However, due to the continuous improvement of product functions, design changes, etc., there may still be discrepancies with the products you buy. Please scan the APP QR code in the instructions, download the product APP for Android or iOS system and read the electronic version of the latest instructions. Due to the product update, the product mentioned in this instructions may be different from the product you actually purchased in terms of color and appearance. Please refer to the actual product.

©Huaian PX Intelligent Manufacturing Co., Ltd. reserves all rights.

2. Product legal Statement

The more familiar you are with this product, the safer you will be when riding. Please pay more attention on the followings:

- (1) Read the product instructions carefully. If you cannot ride the product according to the instructions, please do not attempt to ride the product.
- (2) Please do not allow people who have not read this manual carefully to use the product. When you lend your product to others, you must deliver the product together with the product description, and inform them of the use method and safety tips.
- (3) Purchase insurance in time after purchasing this product, so as to minimize the risk of use.
- (4) You are obliged to be aware of all relevant laws, regulations and policies regarding electric bicycles/scooters/motorcycles in your area and strictly comply with the applicable laws, regulations and policies. Avoid ride in areas that are not allowed by local laws, regulations or policies.
- (5) When you receive this product, please immediately check whether the product and accessories are intact and complete.

Due to the special needs of the bike in the logistics transportation, we will use the packing box to ensure its transportation safety. In order to make you better enjoy the services we provide for you, it is recommended that you keep the packing box for at least 15 days from the date of product receipt.

(6) All PXID products should be assembled correctly according to the instructions, improper installation may bring out of control, collision or fall, please turn off the power before installation or maintenance, in the installation of components, please strength appropriate, installation too loose or too tight may lead to product damage or present fault.

(7) This product may contain detachable parts, which should be protected from harm caused by children swallowing. (8) Before each use of this product, please do according to your purchase model corresponding to instruction manual check tyre performance, the running state of the battery and bike body installation status. To ensure that contains all parts of the brake, screw, nut, there's no sign of loose or damaged, avoid the body or part poor state influence your normal driving, and even accidents.

(9) It is recommended to wear protective glasses when riding, which can prevent dirt, dust and insects in the air. Use lenses of different lightness: dark when fiber is strong, transparent when light is low.

(10) This product can only be loaded by one person. When riding, please keep alert and ride at an appropriate speed. No special effects are allowed during riding or riding.

(11) Do not park the product in the safety exit, evacuation passage and other prohibited parking areas. Do not throw or drop the product. Do not place the product on open flame or under high temperature.

(12) Use the original battery pack and charge the battery with the original charger. Otherwise, the charger or battery may be damaged or safety risks may occur.

(13) When charging, connect the power cable to the correct socket (110V-240V to 50Hz/60Hz), keep it away from children and pets, and keep it away from flammable objects. If the battery is damaged or flooded, do not use the battery after charging it. Do not charge this product when the socket is wet.

(14) It is strictly prohibited to immerse the battery or vehicle body in water or to be exposed to heavy rain or ride in the rain,

so as to avoid water flooding in the battery compartment and circuit chip.

(15) Due to the work of the intelligent system and alarm system of the vehicle, the battery power will be consumed from time to time. After the battery is placed in the vehicle for a period of time, the meter shows that the power decline is normal. If the vehicle is not used for a long time (such as winter, summer or other special circumstances), please store the battery separately and maintain it regularly, otherwise it may cause the battery to run out completely and produce irreversible damage.

(16) Do not store the battery in an environment higher than 50°C or lower than -20°C, otherwise it will cause irreversible capacity decay of the battery.

(17) Please do not store the battery or vehicle in a place with a risk of falling, which may cause uncontrollable damage inside the battery and may lead to leakage, heat, smoke, fire or explosion of the battery.

(18) There are harmful substances in the battery. Please do not try to destroy the battery. The battery is not a repairable part. If the battery has peculiar smell, heat, deformation or other abnormal conditions, please stop using it immediately, keep away from the battery and contact the after-sales department.

(19) Warning: Due to the user's failure to use and maintain the battery normally, the battery performance deteriorates or cannot be used normally, which is not within the scope of the three guarantees.

(20) Improper disposal of used batteries may seriously pollute the environment. Please do not discard the battery pack at will to jointly protect the natural environment. Observe local laws and regulations when disusing battery packs.

(21) Please avoid the use of non-original parts, and do not disassemble, crack or modify the product and parts without authorization. The damage and loss caused by this will be borne by you.

(22) If the product does not belong to the scope of warranty services, you need to pay for maintenance and related services.

(23) If this product and its parts need to be repaired or replaced during use, please keep the relevant after-sales service information after repair or replacement.

(24) Please strictly abide by the traffic laws and regulations in your area. Due to the differences in laws, regulations and policies of registration management and government control in different countries or regions, please confirm the local registration management and control policies and programs before purchase and use, and consult the relevant local management departments for relevant questions. The Company shall not bear any responsibility for any loss caused by the failure of registration or other policies and regulations.

3. Others

(1) Product data and parameters vary with different models and are subject to change without prior notice.

(2) To the extent permitted by law, our Company reserves the right to interpret and explain this Statement.

(3) This Statement shall be governed by the laws of the People's Republic of China (except the laws of Hong Kong and Macao Special Administrative Regions and Taiwan Region of China). The Company shall not be liable for all claims, liabilities and losses arising or likely arising out of the Consumer's breach of the terms of the above statement. Drivers should be responsible for unforeseen or unavoidable risks encountered in the course of driving.

(4) If one day you want to resell or re-gift the product you purchased, please do not forget to forward this legal declaration with you as it is part of the product. If you have any questions, I'm glad to be at your service.

Thank you again for your choice and trust in this product.



www.pxid.com